

APPLICATIONS

The Grundfos CME is a compact booster pump for water supply and boosting in domestic and light commercial applications. The integrated speed controller enables the CME to keep constant pressure in the pipe system.

FEATURES

- Constant pressure via integrated speed control
- Dry run protection with auto-restart
- Easy installation & operation
- Quiet operation (55 dBA)
- Stainless steel construction for long life
- Built-in thermal protection (1 x 240 V)
- Inbuilt non-return valve

CONSTRUCTION

- Stainless steel shaft, impellers and pump housing
- Composite terminal box and fan cover
- All wet components are 304 Stainless Steel

CONTROL PANEL

The CME pump can be operated manually by means of the control panel.

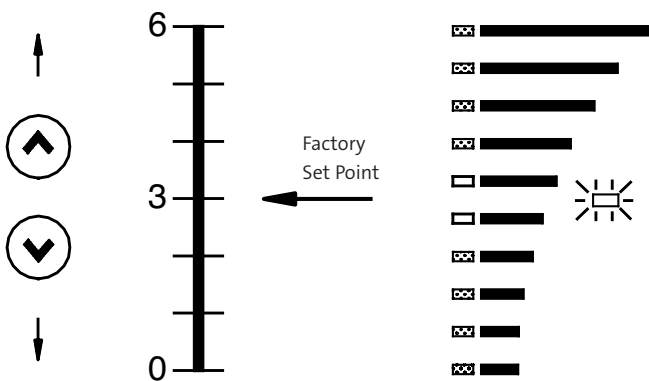

Set the desired setpoint by pressing the \uparrow or \downarrow buttons. The light fields on the control panel will indicate the setpoint set. Continuously pressing the \downarrow button will stop the pump.



PERFORMANCE

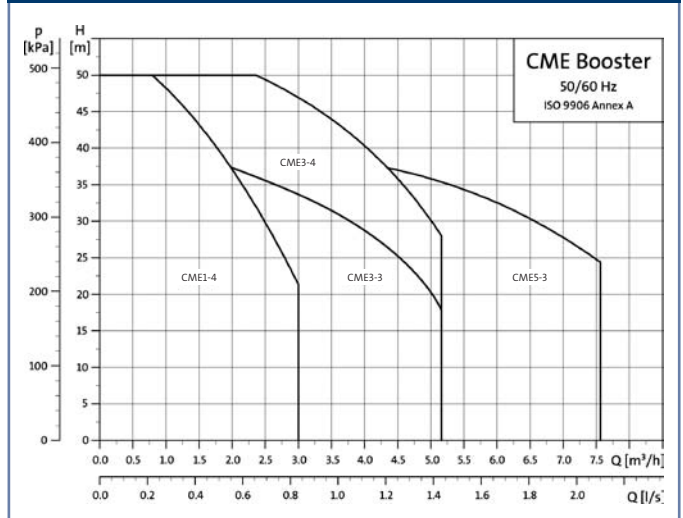

SELECTION

Current CH-PC Model	Suitable Replacement CME*
CH2-50 PC	CME1-4
CH2-60 PC	CME3-3
CH4-40 PC	CME3-3
CH4-50 PC	CME3-4
CH4-60 PC	CME3-4
CHIE4-60	CME3-4
CHIE8-20	CME5-3

*calculated at 3 bar

INSTALLATION

NOTE: Pump must be mounted in a pump shed or building.

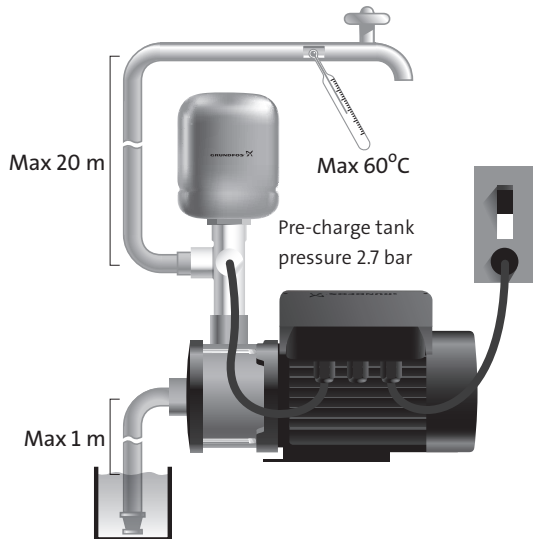

DIMENSIONS

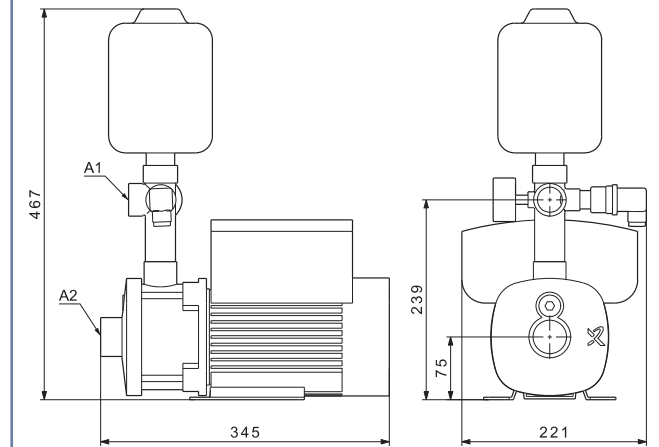

TECHNICAL FEATURES

Pump	P2 (kW)	1ph In (A)	Water temp	Connections		Weight (kg)
				inlet (A2)	outlet (A1)	
CME1-4	0.55	3.4	0/60°C	1"	1"	22
CME3-3	1.10	6.6	0/60°C	1"	1"	23
CME3-4	1.10	6.6	0/60°C	1"	1"	24
CME5-3	1.10	6.6	0/60°C	1 1/4"	1"	23

